

MICROBLUE®



3 YEAR WARRANTY

PERFORMANCE

17dba

MAX FLOW	MAX HEAD	MAX LIFT
5 L/ HOUR	5 METRES	2 METRES

With no additional silencing accessories required, not only is the MICROBLUE® a silent running pump but it can also be mounted in any orientation whilst operating both wet and dry continuously. The MICROBLUE® is a dual voltage pump which uses proven thermistor level sensing technology to remove the risk of stuck or sunken float switches.



UNIT

3.5 KW

SENSING OPTION

MICROBLUE® pump available with:

RESERVOIR	TEMPERATURE SENSOR
X85-001 (HLA-PACK) X85-002 (FSA PACK)	X85-505

FASCIA KIT T18-016
DUCTING KIT X85-507 (FSA-PACK)



PUMPS DEBRIS

The MicroBlue™ is the only ductless pump on the market that can remove sediment/ debris with no need of filters or regular servicing intervals.



NO SILENCING DEVICES

Smooth flow rate from the MicroBlue™ eliminates the necessity for any pulsating free tubing and silencing devices.

PERFORMANCE

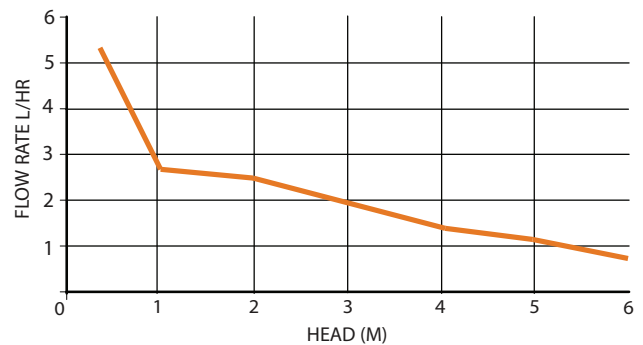

DIMENSIONS (MM)

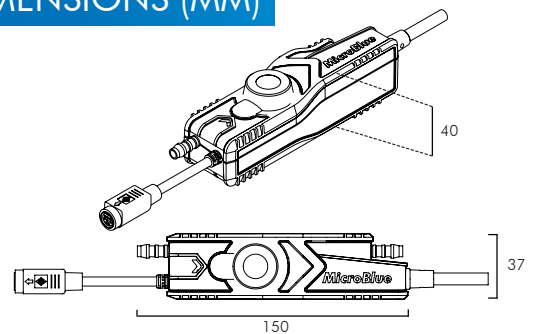

V (VERTICAL)	H (HORIZONTAL)
5 M	0 M
4 M	3 M
3 M	6 M
2 M	9 M
1 M	12 M

The MICROBLUE® can be mounted in any orientation up to 5m away from the air conditioning unit.

DISCHARGE PIPE RUN

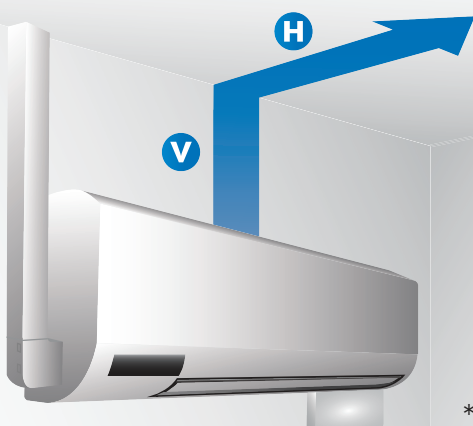

*3.5 KW MAX